

S.NO	CATALOG NUMBER	CONDUCTOR SIZE	SCREW SIZE
1	DSR-2/0K	#2/0 - #14	7/16-20
2	DSR-2K	#2 - #14	5/16-24

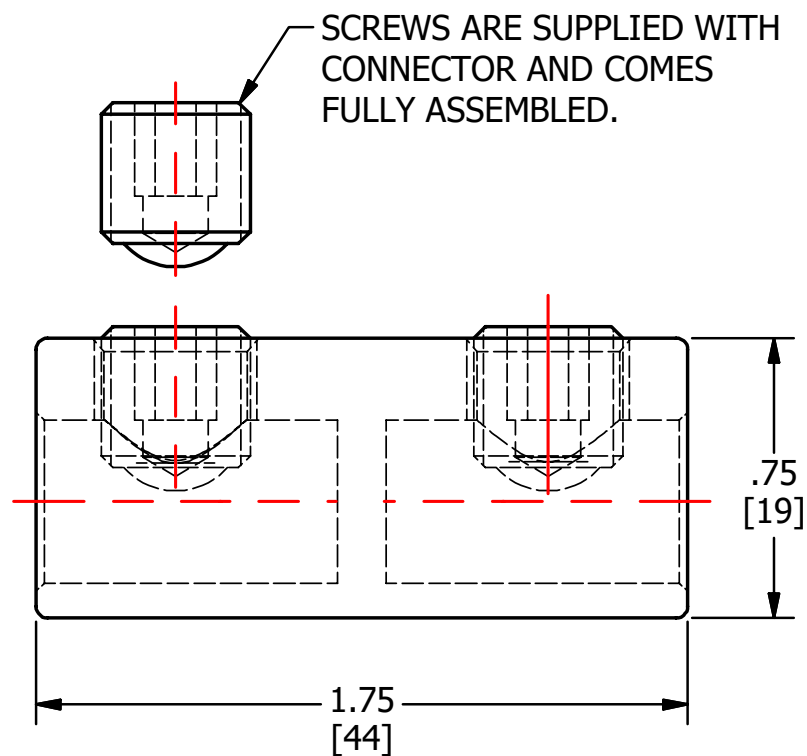

MATERIAL: ALUMINUM

					TO ORDER CMC PRODUCTS CALL 1-513-860-4455	DRAWN BY: TS 08-29-19	NAME OF PART: DOUBLE SPLICER ASSEMBLY	CAT. NO.: SEE TABLE
					FOR PRODUCT INFO: <a href="http://www.cmclugs.com">http://www.cmclugs.com</a>	CHECKED BY:	DWG NO: C58701074-S (CHARTED)	A
A	NEW DRAWING CREATED		08-29-19	TS		DRAWING NOT TO SCALE		SHEET NO: 1 OF 1
REV.	DESCRIPTION	ECN	DATE	INIT.				

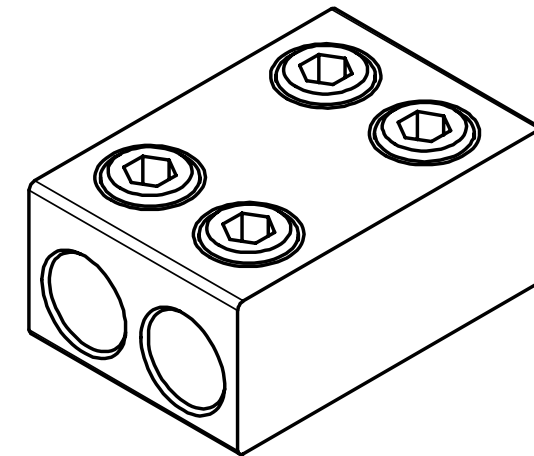
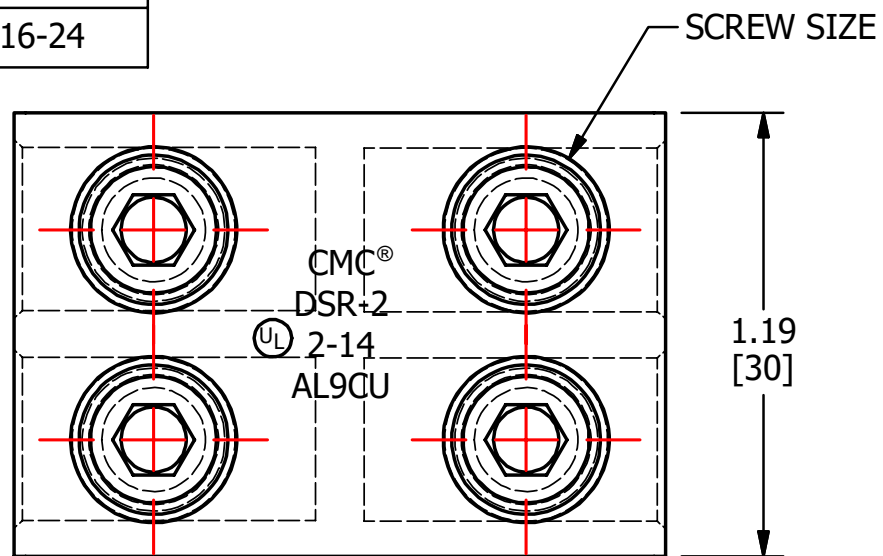